

# Service Schematics

## Introduction

### RM-412/RM-413

**IMPORTANT:**

This document is intended for use by authorized NOKIA service centers only.

“Service Schematics” was created with focus on customer care.  
The purpose of this document is to provide further technical repair information for NOKIA mobile phones on Level 3/4 service activities.  
It contains additional information such as e.g. “Component finder”.

Saving process time and improving the repair quality is the aim of this document.  
It is to be used additionally to the service manual and other training or service information such as Service Bulletins.

While every endeavour has been made to ensure the accuracy of this document, some errors may exist. If the reader finds any errors, NOKIA shall be notified in writing.

Please send E-Mail to: [TrainingAndVendor.Development@nokia.com](mailto:TrainingAndVendor.Development@nokia.com)

#### Table of Contents

|   |   |
|---|---|
| Front page                                  | 1 |
| RAPIDO, USB, Memory, Display, MMC, Sensors  | 2 |
| Betty AVilma, Audio, AV Flex Connector, SIM | 3 |
| Camera, Dynamic Flex Connector              | 4 |
| User Interface (UI)                         | 5 |
| BTHFM, WLAN, GPS                            | 6 |
| RF part                                     | 7 |
| Component finder - Main board               | 8 |

Copyright © NOKIA

This material, including documentation and any related computer programs is protected by copyright, controlled by NOKIA. All rights are reserved. Copying, including reproducing, modifying, storing, adapting or translating any or all of this material requires the prior written consent of NOKIA. This material also contains company confidential information, which may not be disclosed to others without the prior written consent of NOKIA.

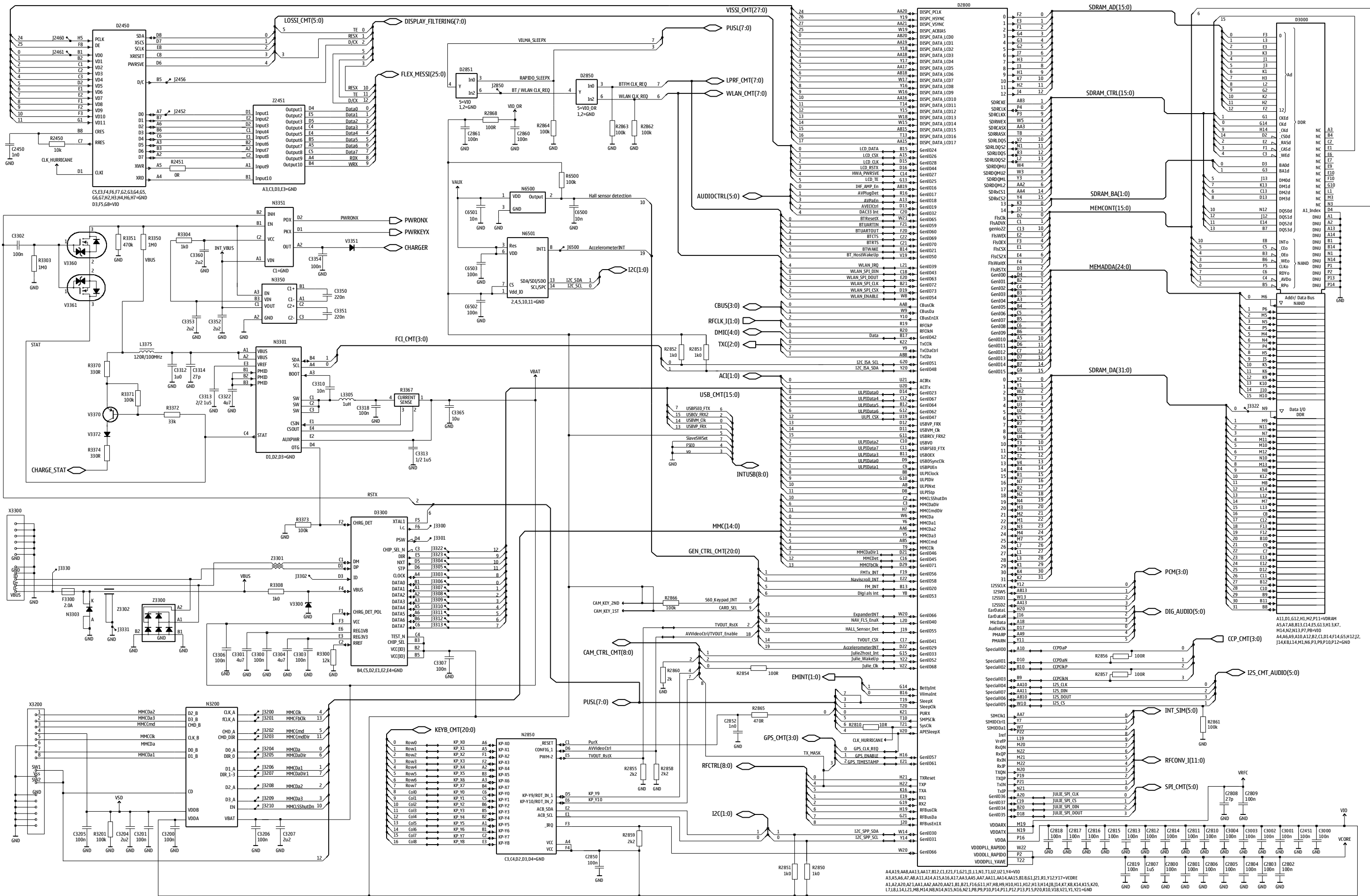

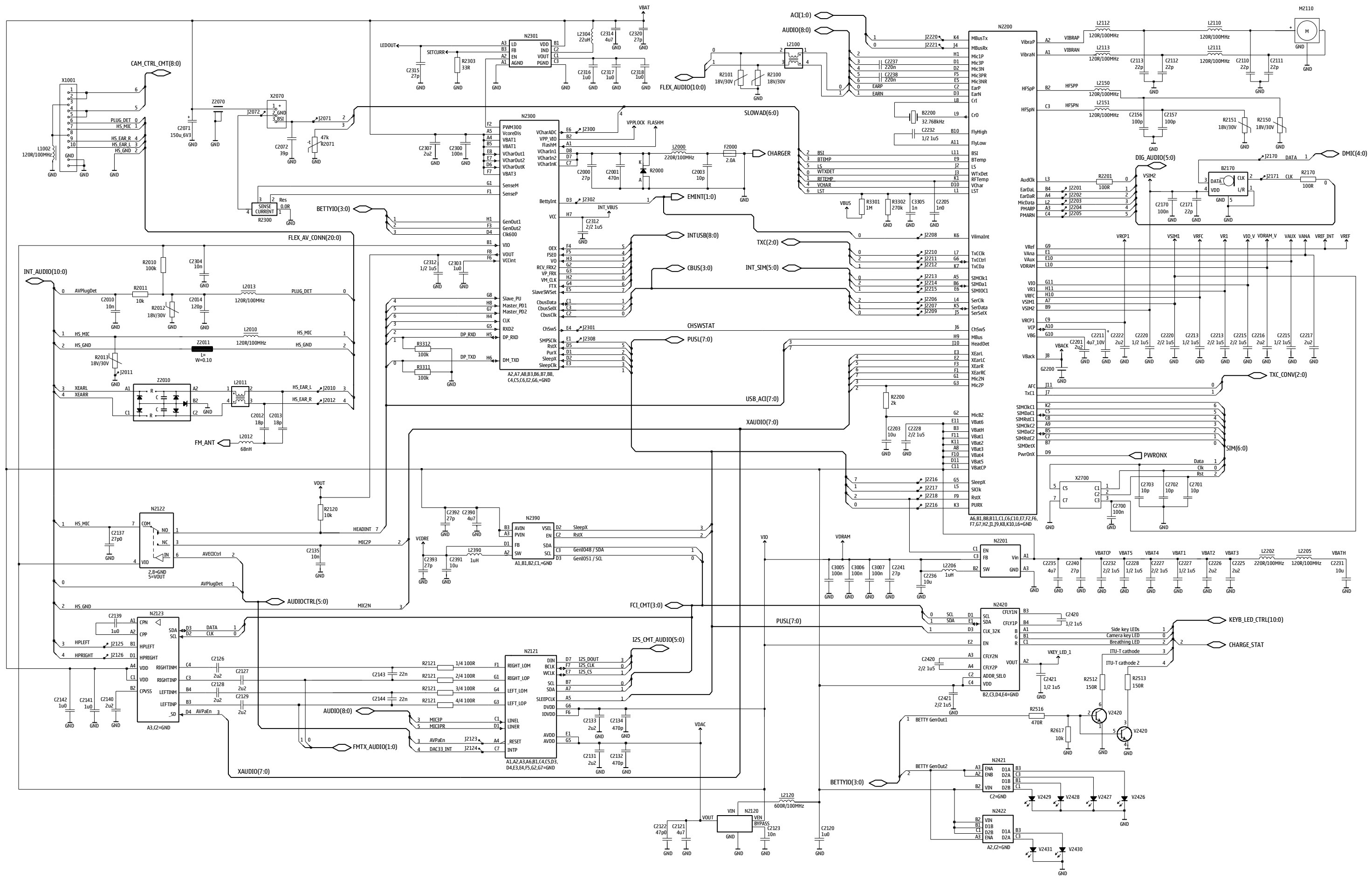

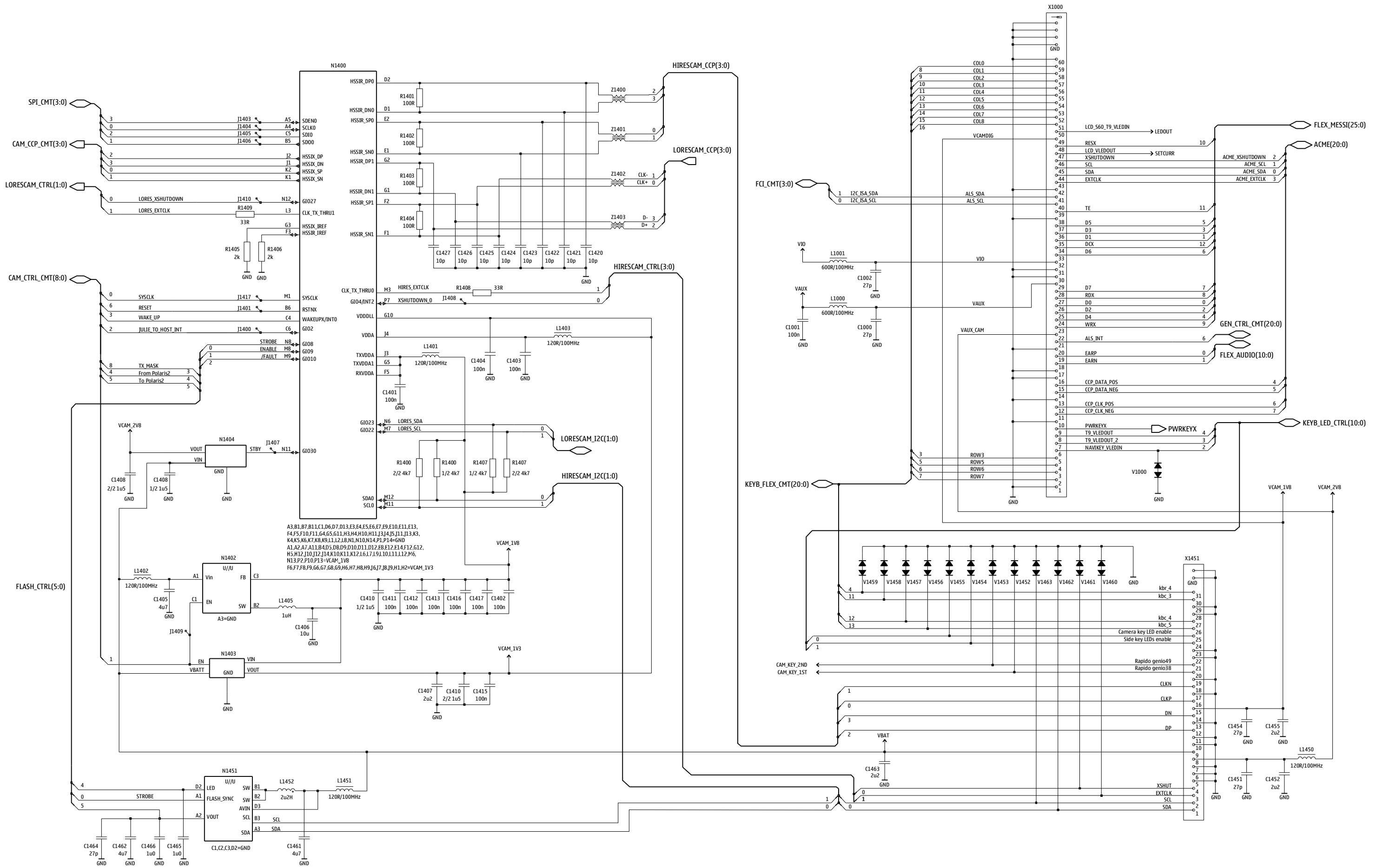

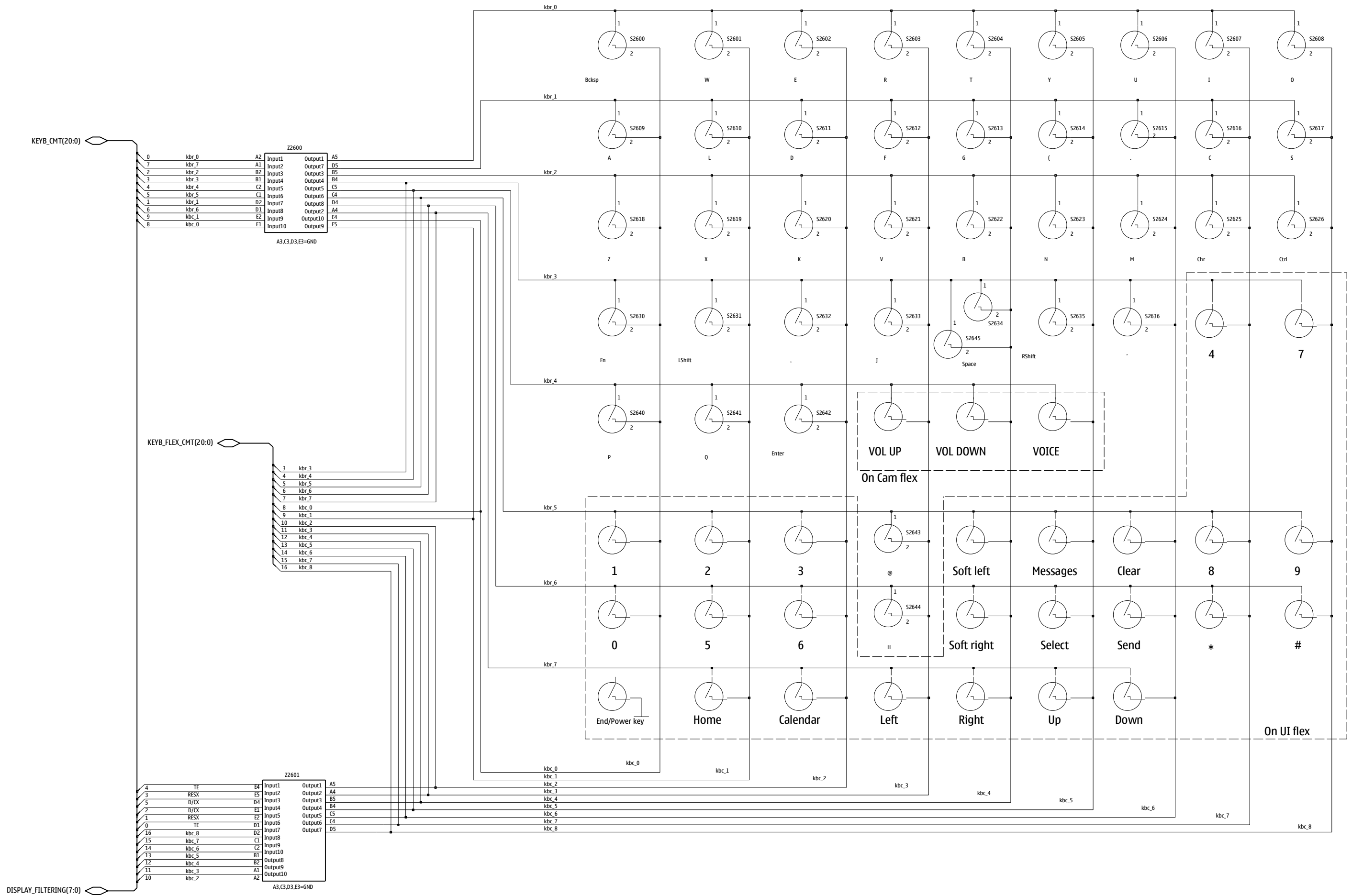

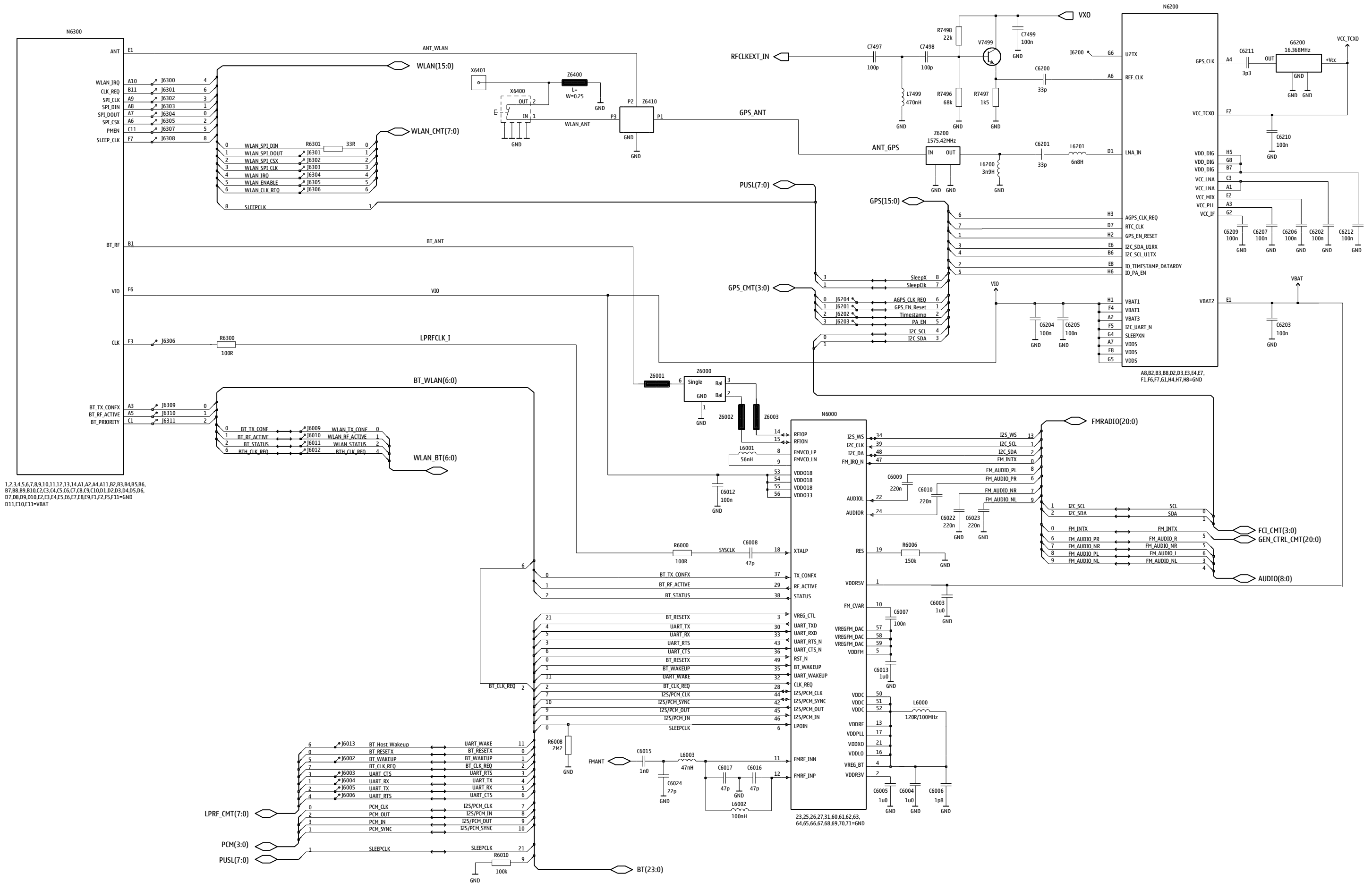

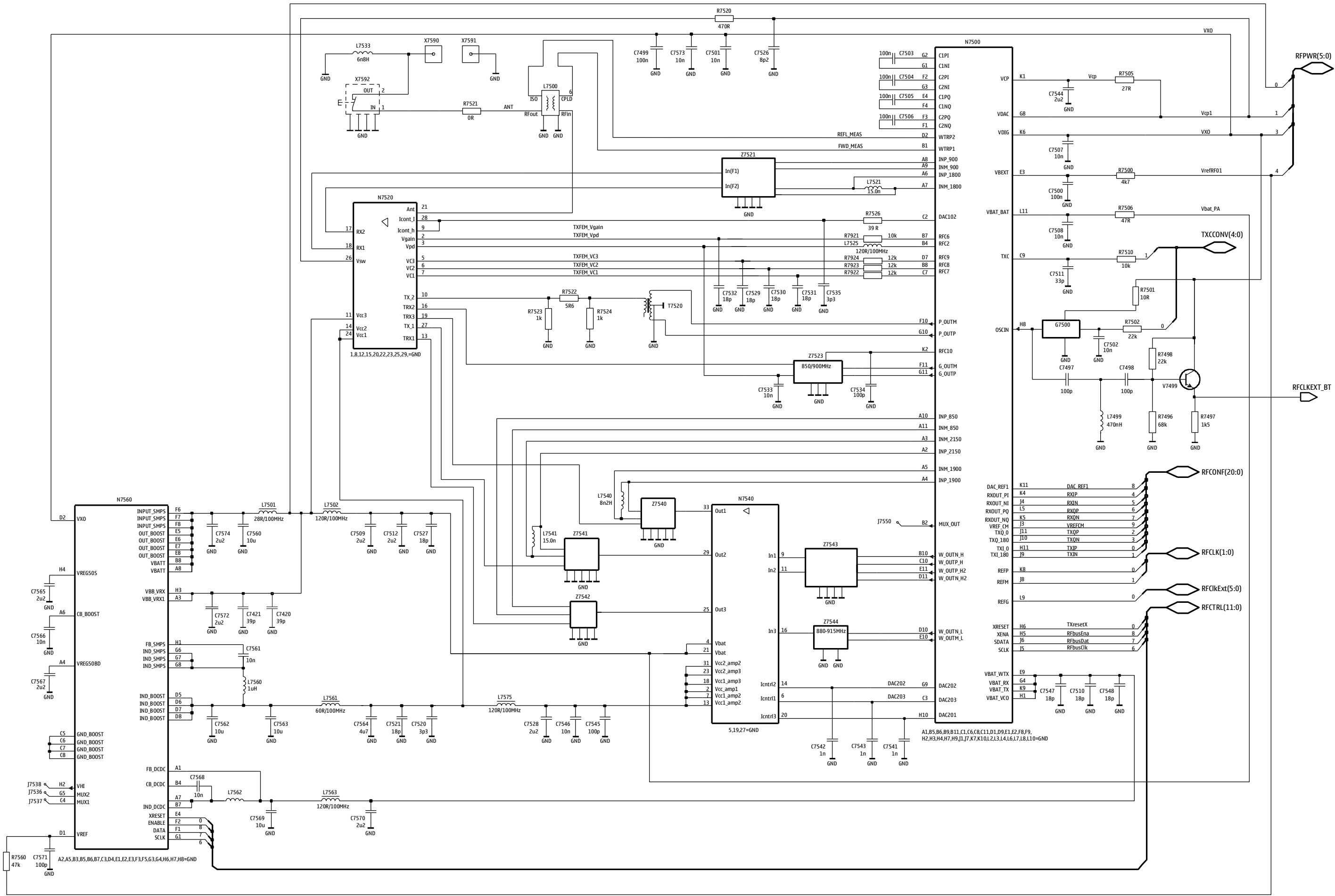

|       |       |       |       |       |       |       |       |       |       |       |       |       |       |       |       |       |     |
|-------|-------|-------|-------|-------|-------|-------|-------|-------|-------|-------|-------|-------|-------|-------|-------|-------|-----|
| A     | C2113 | C13   | C2392 | C11   | C3313 | E14   | C7521 | E6    | L2010 | I21   | N3200 | E16   | R2861 | F10   | V1456 | H13   |     |
| A1000 | H6    | C2120 | F13   | C2393 | D12   | C3314 | F14   | C7526 | D8    | L2011 | H21   | N3301 | E15   | R2862 | D18   | V1457 | I16 |
| A6200 | I7    | C2121 | F14   | C2420 | G5    | C3318 | F14   | C7527 | G6    | L2012 | H19   | N3303 | B18   | R2863 | D19   | V1458 | H13 |
| A6201 | C17   | C2122 | F14   | C2421 | H5    | C3322 | F15   | C7528 | D5    | L2013 | I20   | N3350 | G16   | R2864 | D9    | V1459 | I16 |
| A6202 | E21   | C2123 | F13   | C2450 | I7    | C3350 | H16   | C7529 | E7    | L2100 | H9    | N3351 | G16   | R2865 | G8    | V1460 | H13 |
| A6203 | F13   | C2126 | G15   | C2451 | I7    | C3351 | G16   | C7530 | F7    | L2110 | I18   | N6000 | C17   | R2866 | I13   | V1461 | I13 |
| A6204 | I4    | C2127 | G15   | C2700 | G17   | C3352 | H16   | C7531 | F7    | L2111 | J18   | N6200 | E21   | R2868 | F18   | V1462 | I13 |
| A7500 | E6    | C2128 | F15   | C2701 | E18   | C3353 | G16   | C7532 | E8    | L2112 | C12   | N6300 | E20   | R3201 | E16   | V1463 | I13 |
| B     | C2129 | F15   | C2702 | E18   | C3354 | F16   | C7533 | E7    | L2113 | C12   | N6500 | H4    | R3300 | E13   | V2420 | G4    |     |
| B2170 | I2    | C2131 | F14   | C2703 | E18   | C3360 | F16   | C7534 | C8    | L2120 | G13   | N6501 | E5    | R3301 | C11   | V2426 | F10 |
| B2200 | B10   | C2132 | F14   | C2800 | G11   | C3365 | E14   | C7535 | C6    | L2150 | C12   | N7500 | B6    | R3302 | C11   | V2427 | F15 |
| C     | C2133 | G14   | C2801 | G11   | C6003 | B16   | C7541 | C7    | L2151 | C12   | N7520 | F7    | R3303 | F16   | V2428 | B18   |     |
| C1000 | J9    | C2134 | G15   | C2802 | F10   | C6004 | C16   | C7542 | C7    | L2202 | A10   | N7540 | D6    | R3304 | G16   | V2429 | F20 |
| C1001 | H9    | C2135 | D13   | C2803 | E10   | C6005 | B16   | C7543 | D5    | L2205 | B13   | N7560 | H6    | R3308 | F16   | V2430 | B7  |
| C1002 | J8    | C2137 | C12   | C2804 | D12   | C6006 | C17   | C7544 | A5    | L2206 | C10   | R     | R3311 | D9    | V2431 | F5    |     |
| C1401 | G14   | C2139 | F15   | C2805 | E13   | C6007 | C16   | C7545 | D8    | L2304 | I6    | R1400 | I15   | R3312 | D9    | V3300 | F16 |
| C1402 | H15   | C2140 | G16   | C2806 | F13   | C6008 | C17   | C7546 | C5    | L2390 | C12   | R1401 | H14   | R3350 | F16   | V3351 | G17 |
| C1403 | G15   | C2141 | F15   | C2807 | D10   | C6009 | C17   | C7547 | B5    | L3305 | F15   | R1402 | G14   | R3351 | G17   | V3360 | F16 |
| C1404 | I15   | C2142 | G16   | C2808 | D11   | C6010 | B17   | C7548 | A6    | L3375 | F16   | R1403 | H14   | R3367 | F15   | V3361 | F16 |
| C1405 | H16   | C2143 | G15   | C2809 | D11   | C6012 | B17   | C7560 | G7    | L6000 | B16   | R1404 | H14   | R3370 | E15   | V3370 | E14 |
| C1406 | H16   | C2144 | F15   | C2810 | G12   | C6013 | B17   | C7561 | H7    | L6001 | C16   | R1405 | H14   | R3371 | E15   | V3372 | E14 |
| C1407 | I16   | C2156 | C12   | C2811 | F10   | C6015 | D16   | C7562 | G7    | L6002 | C16   | R1406 | G14   | R3372 | E15   | V7499 | C18 |
| C1408 | I17   | C2157 | C12   | C2812 | G11   | C6016 | C16   | C7563 | G7    | L6003 | D16   | R1407 | I15   | R3373 | E15   | X     |     |
| C1410 | H16   | C2170 | G4    | C2813 | F10   | C6017 | C16   | C7564 | F8    | L6200 | E22   | R1408 | H15   | R3374 | E14   | X1000 | I6  |
| C1411 | I15   | C2171 | H4    | C2814 | E10   | C6022 | B17   | C7565 | G7    | L6201 | E22   | R1409 | H15   | R6000 | C18   | X1001 | H20 |
| C1412 | H16   | C2201 | A11   | C2815 | D11   | C6023 | C17   | C7566 | H6    | L7499 | D18   | R2000 | H4    | R6006 | C17   | X1451 | I15 |
| C1413 | H13   | C2203 | C11   | C2816 | D12   | C6024 | D16   | C7567 | G6    | L7500 | F5    | R2010 | I18   | R6008 | D17   | X2060 | H11 |
| C1415 | H15   | C2205 | B11   | C2817 | E13   | C6200 | E21   | C7568 | H6    | L7501 | H7    | R2011 | J17   | R6010 | E10   | X2070 | C5  |
| C1416 | H15   | C2211 | B12   | C2818 | D10   | C6201 | E22   | C7569 | G5    | L7502 | G6    | R2012 | I21   | R6300 | C18   | X2700 | E18 |
| C1417 | I13   | C2213 | A10   | C2819 | D11   | C6202 | E22   | C7570 | A5    | L7521 | C6    | R2013 | I21   | R6301 | F19   | X3200 | C14 |
| C1420 | G15   | C2215 | A11   | C2850 | H8    | C6203 | F22   | C7571 | G6    | L7525 | C6    | R2071 | B12   | R6500 | I4    | X3300 | A18 |
| C1421 | H15   | C2216 | A11   | C2852 | G8    | C6204 | E21   | C7572 | H7    | L7533 | G3    | R2100 | I6    | R7496 | C18   | X6400 | C23 |
| C1422 | G15   | C2217 | C12   | C2860 | D19   | C6205 | F21   | C7573 | G6    | L7540 | E7    | R2101 | I6    | R7497 | C18   | X6401 | B23 |
| C1423 | G15   | C2220 | B12   | C2861 | E8    | C6206 | E22   | C7574 | H6    | L7541 | E5    | R2120 | D13   | R7498 | C18   | X7590 | G2  |
| C1424 | H14   | C2222 | A12   | C2862 | G8    | C6207 | E21   | D     | L7560 | H7    | R2121 | F14   | R7500 | B5    | X7591 | G3    |     |
| C1425 | G14   | C2225 | A12   | C2863 | G8    | C6209 | F22   | D2450 | I8    | L7561 | G8    | R2150 | D19   | R7501 | A7    | X7592 | F5  |
| C1426 | G14   | C2226 | A10   | C3000 | G13   | C6210 | F22   | D2800 | E11   | L7562 | H5    | R2151 | D19   | R7502 | B7    | Z     |     |
| C1427 | G13   | C2227 | A11   | C3001 | H13   | C6211 | F21   | D2850 | D18   | L7563 | C5    | R2170 | E13   | R7505 | A6    | Z1400 | H15 |
| C1451 | I15   | C2228 | A12   | C3002 | H13   | C6212 | F21   | D2851 | E9    | L7575 | D7    | R2200 | C11   | R7506 | D8    | Z1401 | G15 |
| C1452 | I16   | C2231 | B12   | C3003 | G13   | C6500 | H4    | D3000 | H11   | M     | R2201 | E13   | R7510 | B7    | Z1402 | H13   |     |
| C1454 | I16   | C2232 | A12   | C3004 | I13   | C6501 | I4    | D3300 | E14   | M2110 | I20   | R2300 | B4    | R7520 | F8    | Z1403 | G13 |
| C1455 | I16   | C2235 | C10   | C3005 | H10   | C6502 | F4    | F     | N     | R2303 | J6    | R7521 | F5    | Z2010 | I18   |       |     |
| C1461 | G17   | C2236 | D10   | C3006 | I10   | C6503 | E5    | F2000 | H4    | N1400 | I14   | R2450 | I7    | R7522 | C7    | Z2070 | C4  |
| C1462 | G19   | C2237 | C12   | C3007 | I10   | C7497 | D18   | F3300 | B18   | N1402 | H16   | R2451 | H9    | R7523 | C8    | Z2451 | I9  |
| C1463 | H16   | C2238 | C11   | C3200 | E16   | C7498 | D18   | G     | N1403 | I16   | R2512 | G5    | R7524 | C7    | Z2600 | H5    |     |
| C1464 | G19   | C2240 | C10   | C3201 | E16   | C7499 | C18   | G2200 | I4    | N1404 | I16   | R2513 | G4    | R7525 | A6    | Z2601 | H7  |
| C1465 | G17   | C2241 | D10   | C3204 | E16   | C7500 | B5    | G6200 | D21   | N1451 | G18   | R2516 | F4    | R7526 | C6    | Z3300 | B18 |
| C1466 | G19   | C2300 | C8    | C3205 | F16   | C7501 | A7    | G7500 | B7    | N2120 | F13   | R2617 | G4    | R7560 | G6    | Z3301 | B18 |
| C2000 | H5    | C2303 | D9    | C3206 | E16   | C7502 | B7    | L     | N2121 | G14   | R2810 | D11   | R7921 | C7    | Z3302 | E15   |     |
| C2001 | H4    | C2304 | C9    | C3207 | E16   | C7503 | B5    | L1000 | I9    | N2122 | D12   | R2850 | E10   | R7922 | C6    | Z6000 | D17 |
| C2003 | H4    | C2307 | D8    | C3300 | F14   | C7504 | B5    | L1001 | I8    | N2123 | G15   | R2851 | E10   | R7923 | C7    | Z6200 | D22 |
| C2010 | I17   | C2312 | D8    | C3301 | F14   | C7505 | B5    | L1002 | I21   | N2200 | B11   | R2852 | E10   | R7924 | C7    | Z6410 | B22 |
| C2012 | H20   | C2314 | I5    | C3302 | F16   | C7506 | B5    | L1401 | G14   | N2201 | C10   | R2853 | D12   | T     | Z7521 | C6    |     |
| C2013 | H20   | C2315 | J5    | C3303 | E14   | C7508 | A7    | L1402 | G14   | N2300 | D8    | R2854 | H15   | T7520 | C7    | Z7523 | B7  |
| C2014 | I21   | C2316 | I6    | C3304 | E14   | C7509 | G5    | L1403 | G15   | N2301 | I5    | R2855 | G8    | V     | Z7540 | E6    |     |
| C2071 | B8    | C2317 | I6    | C3305 | C11   | C7510 | B7    | L1405 | H16   | N2390 | D11   | R2856 | F13   | V1000 | H4    | Z7541 | E6  |
| C2072 | E4    | C2318 | I5    | C3306 | E14   | C7511 | B7    | L1450 | I16   | N2420 | G5    | R2857 | F13   | V1452 | I13   | Z7542 | E7  |
| C2110 | I18   | C2320 | I5    | C3307 | E13   | C7512 | D5    | L1451 | G17   | N2421 | F9    | R2858 | H9    | V1453 | I13   | Z7543 | C7  |
| C2111 | J18   | C2390 | D11   | C3310 | F16   | C7514 | A6    | L1452 | G18   | N2422 | E9    | R2859 | G8    | V1454 | I16   | Z7544 | C7  |
| C2112 | C12   | C2391 | D12   | C3312 | E16   | C7520 | G6    | L2000 | H5    | N2850 | H8    | R2860 | D10   | V1455 | H13   |       |     |

